

Self-Contained Freewheels

RDBR-E RDBR-E-H

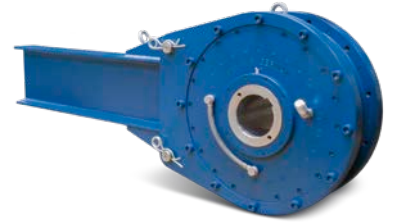

TYPE

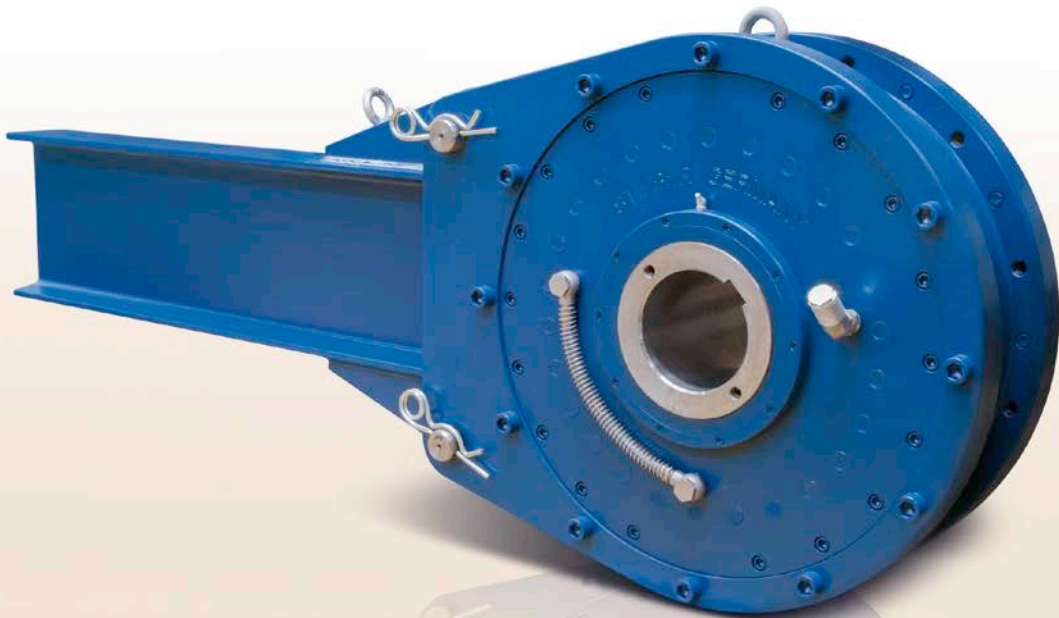

Backstops type RDBR-E are directly mounted on the drive shaft, e.g. of heavy duty conveyer belts, mixing drum drives and chain conveyors, when torque limiting / load sharing or the release function is required.

RDBR-E features a roller type backstop design with a fully bearing supported multidisc brake for the torque limiting function. The optional release function allows the tension of a jammed belt to be controlled released. Once the brake is fully opened, the capability of an unlimited rolling backwards makes maintenance safe and easy.

To activate the release function, a simple hydraulic hand pump or power pack can be used. A mechanical release is available on request. Backstops RDBR-E are self contained and oil lubricated.

A special sealing arrangement with grease packed labyrinth seal guarantees highest reliability under harsh conditions. The recommended shaft fit is H7/f6. The torque arm must not be rigidly fixed to the foundation. For security reasons a stopper in overrunning direction is recommended. When installed, the backstop must be axially secured.

Self-Contained Freewheels

RDBR-E, RDBR-E-H

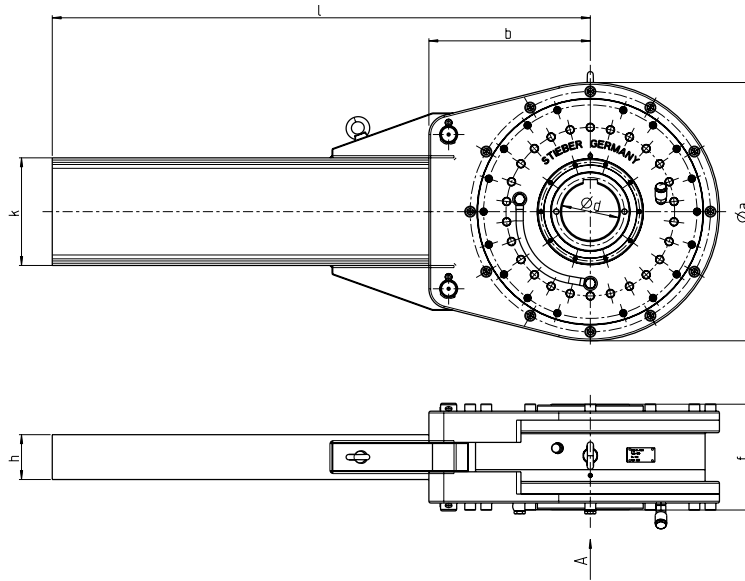

Type	Size											Weight
		$d_{\max}^{H7\ 1)}$ [mm]	$T_r^{2)}$ [kNm]	$n_{\max}^{3)}$ [min ⁻¹]	$n_{r\max}^{4)}$ [min ⁻¹]	a	b	h	k	f	l	[kg]
RDBR...-E RDBR...-E-H	280	150	50	175	175	660	410	119	280	295	1500	690
	300	160	75	150	150	720	450	125	300	295	1500	840
	360	190	120	130	130	780	500	137	340	350	1800	1160
	420	240	180	120	120	880	550	149	380	360	2000	1400
	500	320	330	100	100	1075	670	170	450	390	2200	2390

Sizes with a higher torque capacity are available on request.

NOTES

- 1) Keyway to DIN 6885.1
- 2) Maximal slipping torque.
A lower slipping torque can be set.
- 3) Maximal overrunning speed
- 4) Maximal speed rolling backwards, internal brake opened

When ordering, please specify direction of rotating seen from arrow »A«.
 »R« Inner race overruns in clockwise direction.
 »L« Inner race overruns in counterclockwise Direction

Refer to mounting and maintenance instructions pages 12 to 13

MOUNTING EXAMPLE

