

## Self-Contained Freewheels

# BC MA

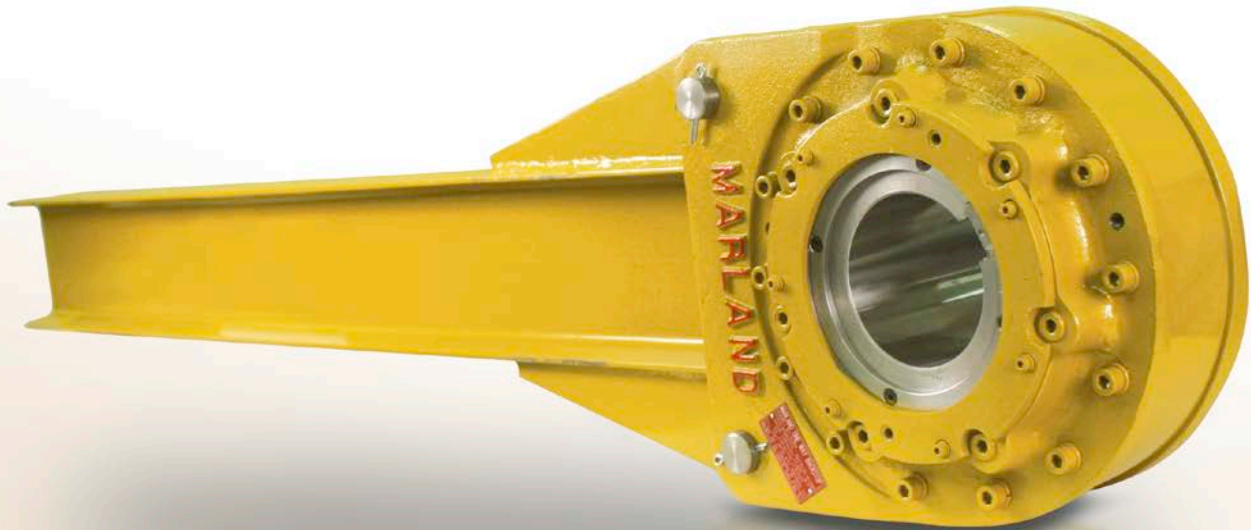

### TYPE



Type BC MA is a roller type backstop, bearing supported and self-contained. Standard lubrication is oil.

This type is designed to be mounted on the drive pulley shaft of large inclined conveyers. It is capable of working in the harsh environment of mine sites. The unit is symmetrical and can be mounted for desired free shaft rotation. The torque arm is a single “I” beam section which is attached to the backstop with two precision ground torque arm pins. This greatly simplifies field installation. The arm may be placed up, down, or at any

angle, and provides uniform loading on both cover plates. The preferred position is horizontal to reduce bearing loading for longer bearing life. The shaft fit should be f6 or f7. The clutch elements and ball bearings are continuously self-lubricated in a sealed oil chamber.

The seal package consists of:

- Double-lip oil seals outside the bearings to keep oil in and dirt out.
- Relubricable grease pocket and all metal graphited labyrinth grease seal.

Detailed catalog on request.

# Self-Contained Freewheels

**BC MA**

**BC MA**

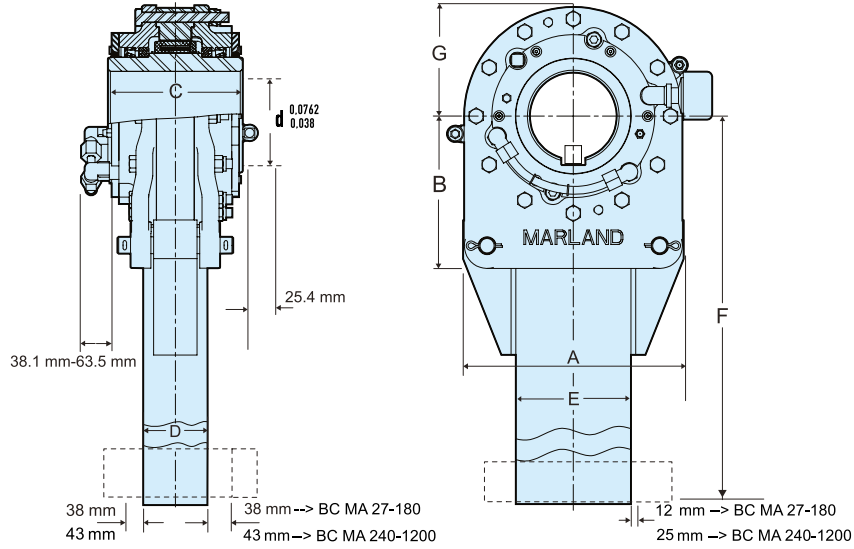

Type	Size	Bore	Overrunning Speed									Weight	
BC		$d_{max}$	$T_{KN}^{1)}$ [Nm]	$n_{max}$ [min <sup>-1</sup> ]	A [mm]	B [mm]	C [mm]	D [mm]	E [mm]	F [mm]	G [mm]	[kg]	
		27MA	165	36 607	150	384	254	222	98	178	1676	191	207
		45MA	180	61 012	135	445	289	235	105	203	1829	216	276
		63MA	205	85 417	120	498	311	244	127	254	1981	244	381
		90MA	235	122 024	105	584	362	276	140	305	2083	270	520
		135MA	265	183 035	90	654	406	314	143	381	2235	308	690
		180MA	300	244 047	80	772	419	330	159	457	2388	349	966
		240MA	360	325 396	70	876	457	387	162	508	2540	413	1242
		300MA	360	406 745	70	876	457	413	162	508	2745	413	1720
		375MA	460	508 432	60	1041	584	445	203	622	3048	495	2760
		540MA	540	732 142	60	1194	673	527	257	692	3658	578	4140
		720MA	540	976 271	60	1194	673	552	257	692	3658	578	4545
		940MA	540	1 274 600	60	1220	700	584	257	692	3960	610	5455
	1200MA	600	1 626 000	60	1320	750	625	267	762	4267	660	6591	

## NOTES

1)  $T_{max} = 1,75 \times T_{KN}$

Inch bore available on request  
Keyway to DIN 6885.1  
For size 1200MA TBD

For more details see separate catalog.

» Refer to mounting and maintenance instructions  
page 12 to 13

## MOUNTING EXAMPLE

