

Built-In Freewheels

AA



TYPE



Type AA is a roller type freewheel non-bearing supported. Bearings are required to support axial and radial loads. Lubrication and sealing must also be provided by the installation.

Standard lubrication is oil. A typical installation is shown on the following page.

The inner race is keyed to the shaft. The fit for centering of the outer race must be to H7 tolerance. Connection of the outer race is via through bolts to grade 10.9 or better.

This design can accept an axial misalignment of inner and outer race of $\pm S/2$.

AA

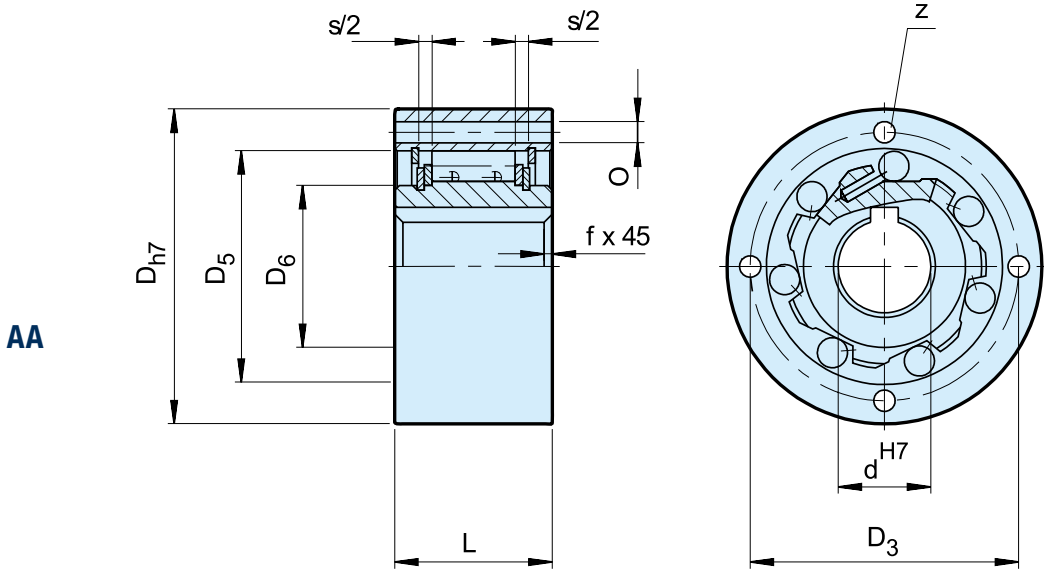

Type	Size	Overrunning speeds ¹⁾						Number	Z	O	L	f	s	Weight	Drag torque
		$T_{KN}^{1)}$ [Nm]	$n_{imax}^{2)}$ [min ⁻¹]	$n_{amax}^{3)}$ [min ⁻¹]	D_{h7} [mm]	D_5 [mm]	D_6 [mm]								
AA	12	17	3100	6200	47	28	20	38	3	5,5	20	0,5	4,5	0,21	0,7
	15	55	2300	5600	55	37	26	45	3	5,5	30	0,8	4,5	0,44	3,5
	20	146	2000	4800	68	50	35	58	4	5,5	34	0,8	5,5	0,70	8,4
	25	285	1700	4000	90	68	45	78	6	5,5	37	1	6,5	1,30	14
	30	500	1500	3400	100	75	50	87	6	6,6	44	1	6,5	2,00	23
	35	720	1300	2800	110	80	55	96	6	6,6	48	1	6,5	2,60	60
	40	1030	1200	2500	125	90	60	108	6	9	56	1,5	7,6	3,90	72
	45	1125	1050	2200	130	95	65	112	8	9	56	1,5	7,6	4,00	140
	50	2150	950	2050	150	110	75	132	8	9	63	1,5	7,6	6,00	180
	55	2675	850	1950	160	115	82	138	8	11	67	2	7,6	7,20	190
	60	3500	800	1800	170	125	90	150	10	11	78	2	7,6	9,20	240
	70	5813	650	1700	190	140	100	165	10	11	95	2,5	7,6	11,8	320
	80	6250	500	1500	210	160	115	185	10	11	100	2,5	7,6	15,6	330
	90	10750	400	1300	230	180	130	206	10	14	115	3	7,6	24,7	650
	100	15000	350	1150	270	210	150	240	10	18	120	3	7,6	35,8	830
	120	25000	230	900	310	240	180	278	12	18	140	4	9,6	54,3	1080
	150	57500	160	600	400	310	230	360	12	22	180	4	9,6	116	1240
200	135000	125	460	520	400	260	460	18	26	240	5	10,6	267	3800	
250	225000	100	380	610	480	320	545	20	33	300	5	10,6	461	6100	

NOTES

1) $T_{max} = 2 \times T_{KN}$
 » Refer to Selection page 7 to 11

2) Inner race overruns

3) Outer race overruns

Keyway to DIN 6885.1
 » Refer to mounting and maintenance instructions
 page 12 to 13

MOUNTING EXAMPLE

